

PER:
FOR:

ABLOY (SF)

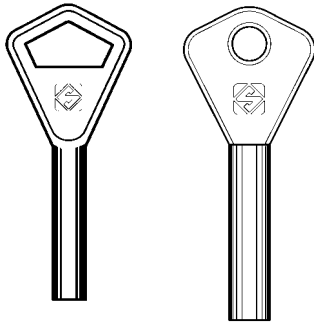

AY1

AY2

OPTIONAL

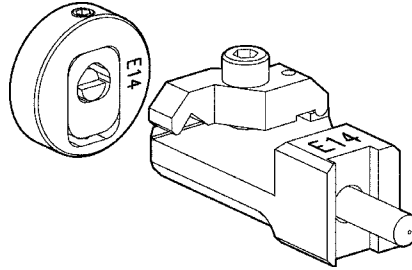

D730698ZB

Adapters for ABLOY keys
Adattatori per chiavi ABLOY
Adapters für ABLOY Schlüssel
Adaptateurs pour clés ABLOY
Adaptadores para llaves ABLOY

PER:
FOR:

ABUS (D)



AB38P

OPTIONAL

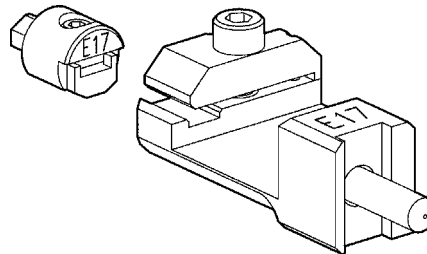

D730697ZB

Adapters for ABUS keys
Adattatori per chiavi ABUS
Adapters für ABUS Schlüssel
Adaptateurs pour clés ABUS
Adaptadores para llaves ABUS

PER:
FOR:

FORD (EU+USA)

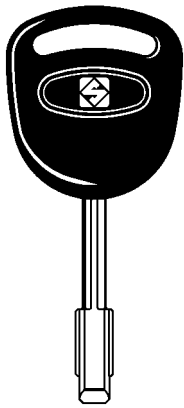

FO21P
FO21PL
FO21T3
FO21T3L
FO21T17
FO21T7
FO21T3M
FO21EH1



FO21AP

IMPORTANT!

KEY BLANK TO BE APPLIED TO THE ORIGINAL REMOTE CONTROL
(THE REMOTE CONTROL INCLUDES THE TRANSPONDER CHIP)

OPTIONAL

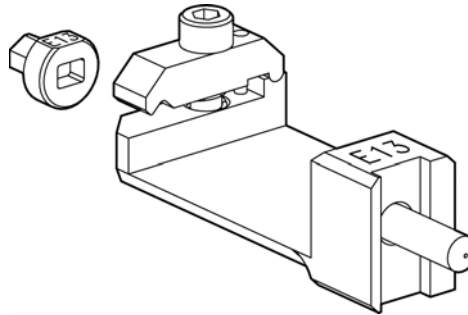

D730302ZB

Adapters for TIBBE FO21 keys
Adattatori per chiavi TIBBE FO21
Adapters für TIBBE FO21 Schlüssel
Adaptateurs pour clés TIBBE FO21
Adaptadores para llaves TIBBE FO21

PER:
FOR:

PUMP KEYS CHIAVI A POMPA PUMPENSCHLÜSSEL CLÉS À POMPE LLAVES A BOMBA

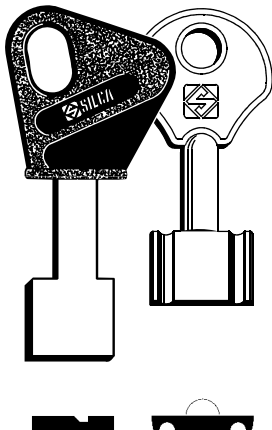

OPTIONAL

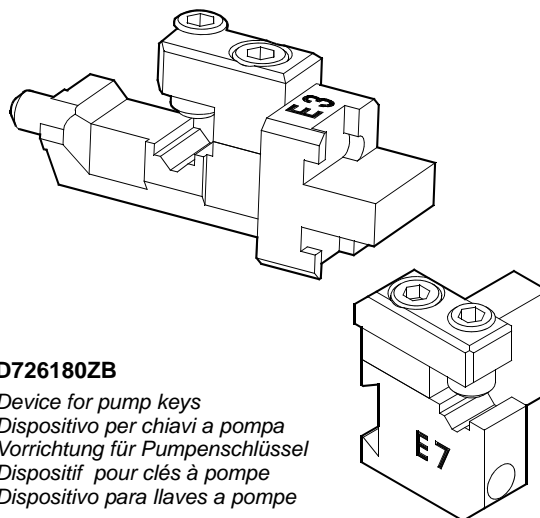

D726180ZB

Device for pump keys
Dispositivo per chiavi a pompa
Vorrichtung für Pumpenschlüssel
Dispositif pour clés à pompe
Dispositivo para llaves a bomba

PER:
FOR:

CHUBB (GB)

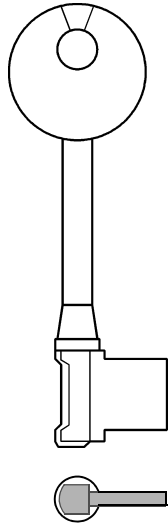

OPTIONAL

CODE

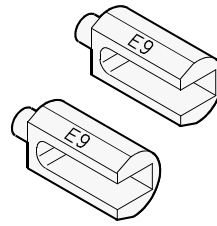

D716544ZB

Adaptors for CHUBB keys with square section stem
 Adattatori per chiavi CHUBB con gambo a sezione quadra
 Adapters für CHUBB Schlüssel mit Schaft mit quadratischem Querschnitt
 Adaptateurs pour clés CHUBB avec tige à section carrée
 Adaptadores para llaves CHUBB con vastago de sección cuadrada

PER:
FOR:

CHUBB (GB)

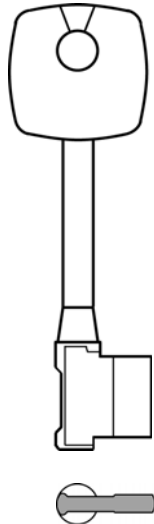

OPTIONAL

CODE

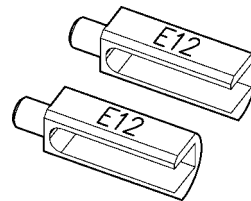

D729920ZB

Adaptors for CHUBB DETAINER keys
 Adattatori per chiavi CHUBB DETAINER
 Adapters für CHUBB DETAINER Schlüssel
 Adaptateurs pour clés CHUBB DETAINER
 Adaptadores para llaves CHUBB DETAINER

PER:
FOR:

CHUBB (GB)

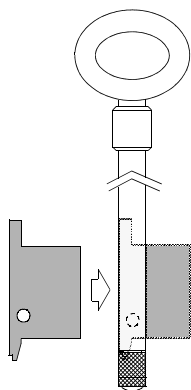

OPTIONAL

COPY



D714422ZB

Adaptors for CHUBB keys bit
 Adattatori per mappe chiavi CHUBB
 Adapters für Bartschlüssel CHUBB
 Adaptateurs pour pannetons des clés CHUBB
 Adaptadores para llaves CHUBB

PER:
FOR:

FIAM (I)

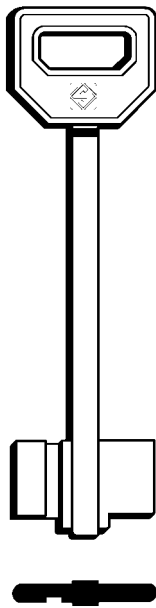

OPTIONAL

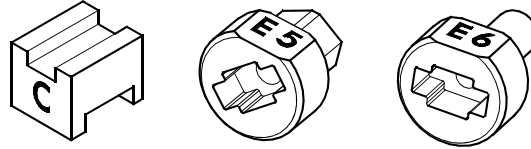

D726462ZB

Device for FIAM keys
Dispositivo per chiavi FIAM
Vorrichtung für FIAM Schlüssel
Dispositif pour clés FIAM
Dispositivo para llaves FIAM

PER:
FOR:

FAS (S)

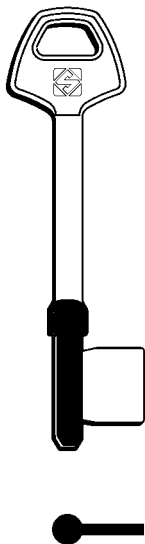

6FS1

(309 - Plastic stem)

OPTIONAL



D727713ZB

Device for FAS keys
Dispositivo per chiavi FAS
Vorrichtung für FAS Schlüssel
Dispositif pour clés FAS
Dispositivo para llaves FAS

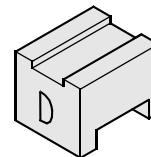

+

D727058ZB

E1 jaw
Morsetto E1
E1 Spannbacke
Etau E1
Mordaza E1

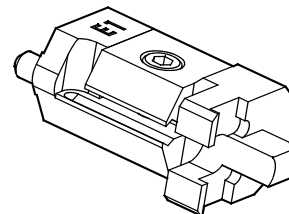

+



D711802ZB

Spacer for FAS keys with plastic stem
Distanziale per chiavi FAS con gambo in plastica
Entfernungstück für FAS Schlüssel mit Plastshaft
Entretoise pour clés FAS avec la tige en plastique
Estancador para llaves FAS con pala en material plástico

PER:
FOR:

FAS (S)

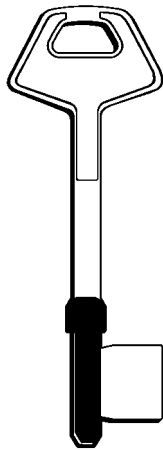

FAS EVOLUTION

OPTIONAL



D733998ZB

Adapters for FAS EVOLUTION keys
Adattatori per chiavi FAS EVOLUTION
Adapters für FAS EVOLUTION Schlüssel
Adaptateurs pour clés FAS EVOLUTION
Adaptadores para llaves FAS EVOLUTION

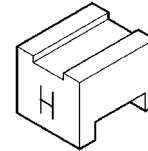

+

D727058ZB

E1 jaw
Morsetto E1
E1 Spannbacke
Etau E1
Mordaza E1

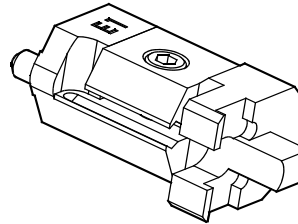

+



D711802ZB

Spacer for FAS keys with plastic stem
Distanziale per chiavi FAS con gambo in plastica
Entfernungsstück für FAS Schlüssel mit Plasthaft
Entretoise pour clés FAS avec la tige en plastique
Estancador para llaves FAS con pala en material plástico

PER:
FOR:

FAS (S)

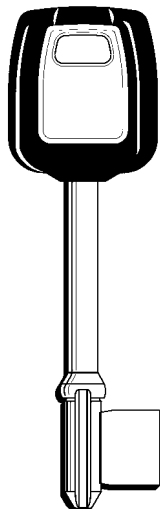

(389)

OPTIONAL

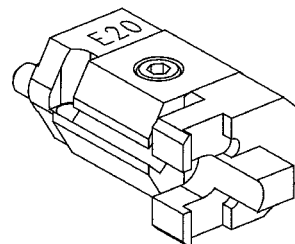



D732174ZB

Adapters for FAS keys
Adattatori per chiavi FAS
Adapters für FAS Schlüssel
Adaptateurs pour clés FAS
Adaptadores para llaves FAS

PER:
FOR:

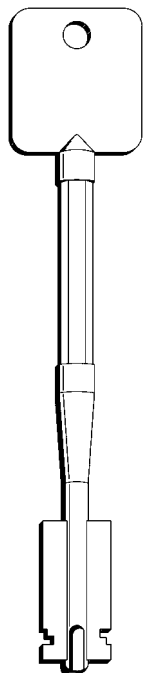
FAS (S)



(S&G 6880)

OPTIONAL

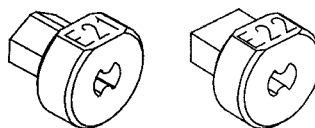

D732178ZB

Centering adapters for FAS keys
Centratori per chiavi FAS
Zentrier-Adapter für FAS Schlüssel
Centreurs pour clés FAS
Centradores para llaves FAS

PER:
FOR:

KROMER (D)

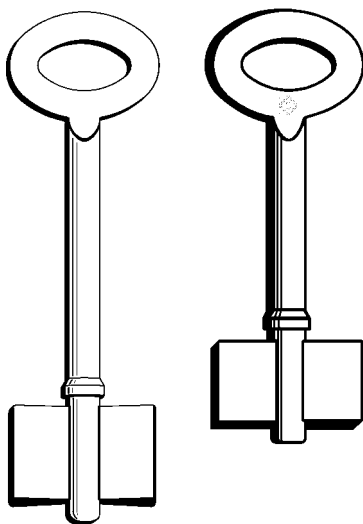

G85K



G86K

OPTIONAL

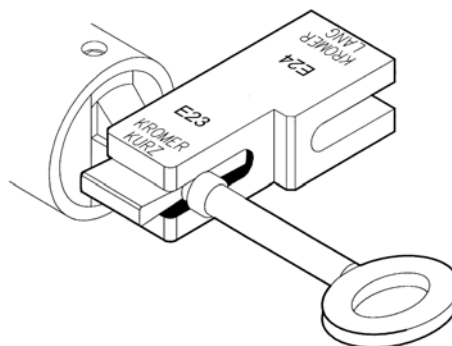
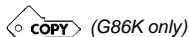

D711216ZB

Template for Kromer keys (long and short)
Dima per chiavi Kromer (lunghe e corte)
Schablone für Kromer Schlüssel (lang und kurz)
Gabarit pour clés Kromer (long et court)
Plantilla para llaves Kromer (largas y cortas)

PER:
FOR:

MUEL (F)

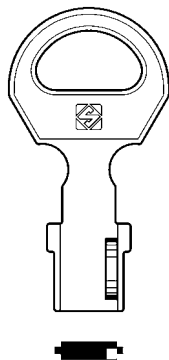

MU6-1	MU7-1	MU8-1	MU10-1
MU6-2	MU7-2	MU8-2	MU10-2
MU6-3	MU7-3	MU8-3	MU10-3
MU6-4	MU7-4	MU8-4	MU10-4
MU6-5	MU7-5	MU8-5	MU10-5
MU6-6	MU7-6	MU8-6	MU10-6
MU6-0	MU7-7	MU8-7	MU10-7
	MU7-0	MU8-8	MU10-8
	MU7-11		MU10-9
	MU7-21		MU10-10
	MU7-22		

OPTIONAL



SN 328
SN 329
SN 352

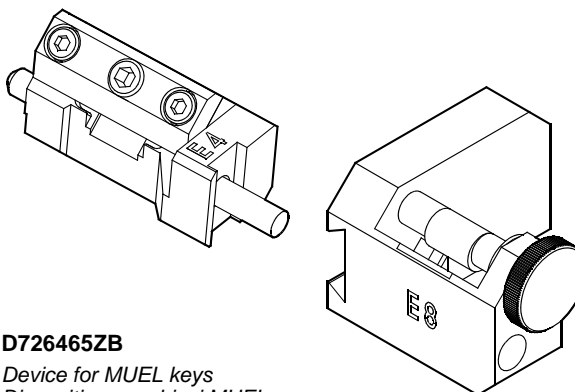

D726465ZB

Device for MUEL keys
Dispositivo per chiavi MUEL
Vorrichtung für MUEL Schlüssel
Dispositif pour clés MUEL
Dispositivo para llaves MUEL

PER:
FOR:

Small bit/double bit keys
Chiavi mappa/doppia mappa (piccole)
Kleine Bart/Doppelbartschlüssel
Petites clés à panneton/double panneton
Llaves paletón/doble paletón pequeños

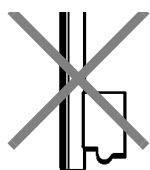
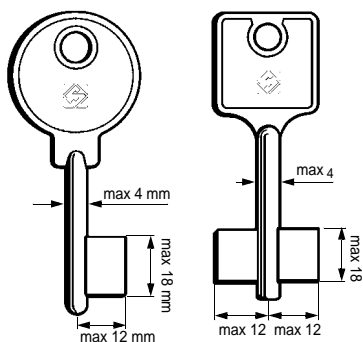

OPTIONAL

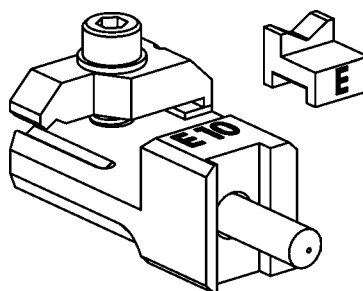

D727711ZB

Adaptors for small bit/double bit keys
Adattatori per chiavi a mappa/doppia mappa (piccole)
Adapters für kleine Bart/Doppelbartschlüssel
Adaptateurs pour petites clés à panneton/double panneton
Adaptadores para llaves paletón/doble paletón pequeños

PER:
FOR:

Rear stop keys
Chiavi con fermo posteriore
Schlüssel mit Hinterem Anschlag
Clés à butée arrière
Llaves con tope posterior

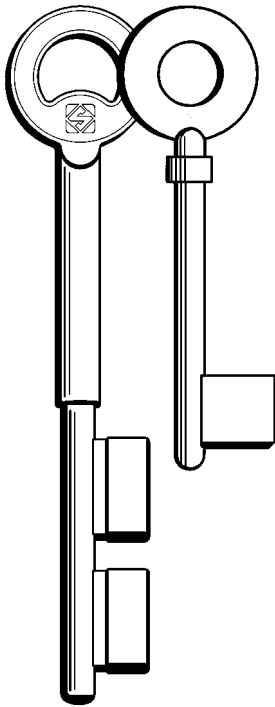

OPTIONAL

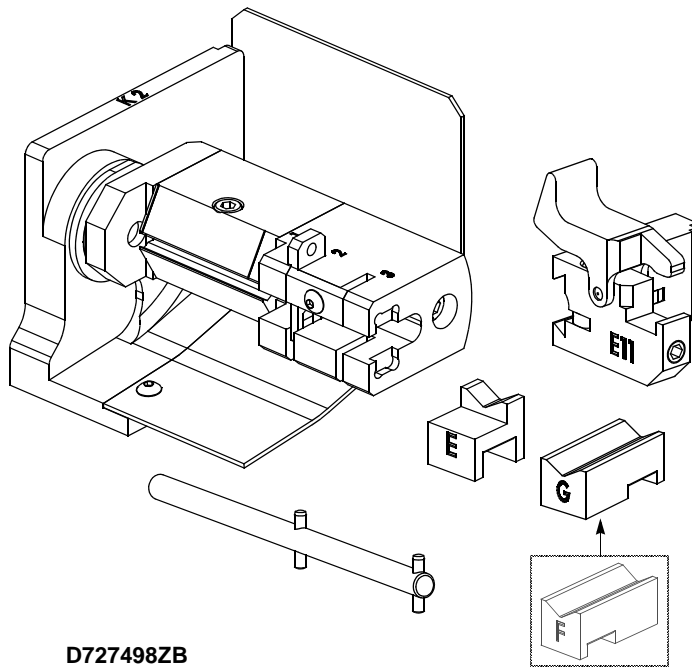

D727498ZB

Set for rear stop keys
Dispositivo per chiavi con fermo posteriore
Vorrichtung für Schlüssel mit Hinten Anschlag
Dispositif pour clés avec butée arrière
Dispositivo para llaves con tope posterior

PER:
FOR:

Special bit female keys
Chiavi fermo anteriore femmina speciali
Gebohrten Schlüssel Spez.
Clés à butée avant femelles spéc.
Llaves tope anterior hembras especiales

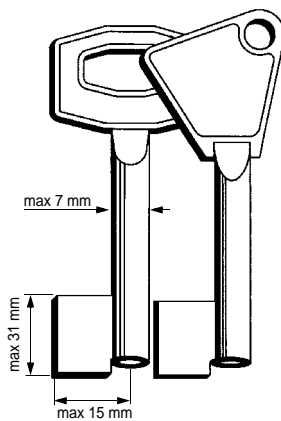

OPTIONAL

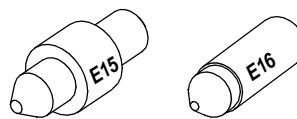

D728717ZB

Adaptor set
Set adattatori
Adapters
Adaptateurs
Adaptadores

ATTENTION: for repairs or replacement of parts for maintenance, the 'CE' mark is guaranteed only if original spare parts provided by the manufacturer are used.

ATTENZIONE: in caso di riparazioni o sostituzione di pezzi per manutenzione, la marcatura "CE" è garantita solo se vengono utilizzate parti di ricambio originali fornite dal costruttore.

ACHTUNG: bei Reparaturen oder Auswechseln von Teilen zur Instandhaltung wird die CE-Markierung nur bei Verwendung von vom Hersteller gelieferten Originalersatzteilen gewährleistet.

ATTENTION: si vous effectuez des réparations ou que vous remplacez des pièces pendant un entretien, le marquage "CE" n'est garanti que si vous utilisez des pièces de rechange originales fournies par le fabricant.

ATENCIÓN: en caso de reparaciones o sustituciones de las piezas por mantenimiento, se garantiza la marca "CE" sólo si se utilizan partes de repuesto originales suministradas por el constructor.



SILCA S.p.A.
Via Podgora, 20 (Z.I.) 31029 VITTORIO VENETO (TV)
Tel. 0438 9136 Fax 0438 913800
www.silca.biz

Member of the Kaba Group

KABA®